

(12) INTERNATIONAL APPLICATION PUBLISHED UNDER THE PATENT COOPERATION TREATY (PCT)

(19) World Intellectual Property Organization
International Bureau



(43) International Publication Date
19 December 2002 (19.12.2002)

PCT

(10) International Publication Number
WO 02/100460 A2

- (51) International Patent Classification⁷: A61M (71) Applicant (for all designated States except US): PE-
LIKAN TECHNOLOGIES, INC. [US/US]; 1072 East
Meadow Circle, Palo Alto, CA 94303 (US).
- (21) International Application Number: PCT/US02/19058
- (22) International Filing Date: 12 June 2002 (12.06.2002) (72) Inventors; and
(75) Inventors/Applicants (for US only): ALDEN, Don
[US/US]; 1312 Nelson Way, Sunnyvale, CA 94087 (US).
FREEMAN, Dominique, M. [GB/US]; 4545 La Honda
Road, La Honda, CA 94020 (US).
- (25) Filing Language: English
- (26) Publication Language: English
- (30) Priority Data: 60/298,055 12 June 2001 (12.06.2001) US (74) Agents: TUNG, Hao, Y. et al.; Heller, Ehrman White &
McAuliffe LLP, 275 Middlefield Road, Menlo Park, CA
94025-3506 (US).
- (63) Related by continuation (CON) or continuation-in-part
(CIP) to earlier application: US 60/289,055 (CIP) (81) Designated States (national): AE, AG, AL, AM, AT, AU,
AZ, BA, BB, BG, BR, BY, BZ, CA, CH, CN, CO, CR, CU,
CZ, DE, DK, DM, DZ, EC, EE, ES, FI, GB, GD, GE, GH,
GM, HR, HU, ID, IL, IN, IS, JP, KE, KG, KP, KR, KZ, LC,
LK, LR, LS, LT, LU, LV, MA, MD, MG, MK, MN, MW,
- Filed on 12 June 2001 (12.06.2001)

[Continued on next page]

(54) Title: ELECTRIC LANCET ACTUATOR

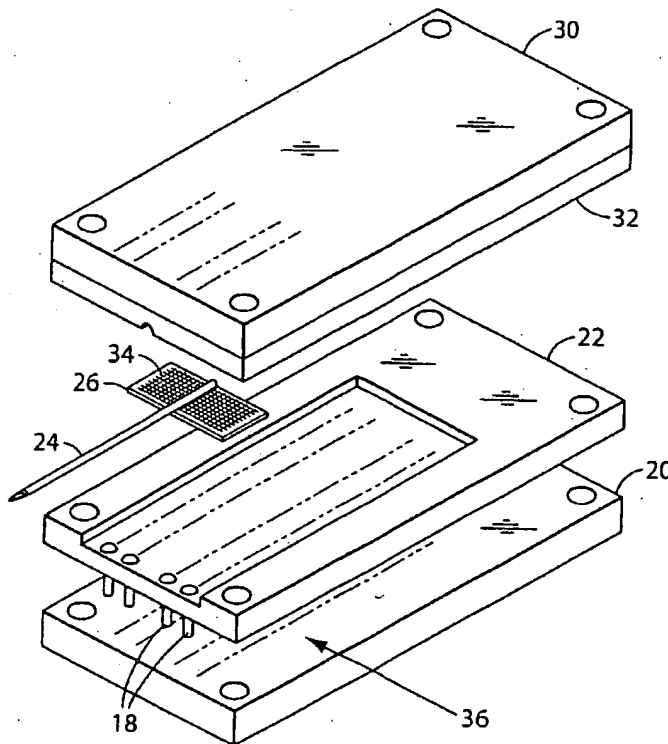

(57) Abstract: An electric lancet actuator and method of using same. An embodiment provides control of a lancet used for sampling blood by puncturing the skin. The lancet can be contained within a stationary housing which interacts with the proximal or driving end of lancet and allows the distal or front end of the lancet to protrude beyond the stationary housing and puncture the skin. Electric field coils or solenoids drive the lancet using either magnetic attraction or repulsion.

WO 02/100460 A2



MX, MZ, NO, NZ, OM, PH, PL, PT, RO, RU, SD, SE, SG, SI, SK, SL, TJ, TM, TN, TR, TT, TZ, UA, UG, US, UZ, VN, YU, ZA, ZM, ZW.

(84) **Designated States (regional):** ARIPO patent (GH, GM, KE, LS, MW, MZ, SD, SL, SZ, TZ, UG, ZM, ZW), Eurasian patent (AM, AZ, BY, KG, KZ, MD, RU, TJ, TM), European patent (AT, BE, CH, CY, DE, DK, ES, FI, FR, GB, GR, IE, IT, LU, MC, NL, PT, SE, TR), OAPI patent (BF, BJ, CF, CG, CI, CM, GA, GN, GQ, GW, ML, MR, NE, SN, TD, TG).

Declaration under Rule 4.17:

— as to the applicant's entitlement to claim the priority of the earlier application (Rule 4.17(iii)) for the following designations AE, AG, AL, AM, AT, AU, AZ, BA, BB, BG, BR, BY, BZ, CA, CH, CN, CO, CR, CU, CZ, DE, DK, DM, DZ, EC, EE, ES, FI, GB, GD, GE, GH, GM, HR, HU, ID, IL, IN,

IS, JP, KE, KG, KP, KR, KZ, LC, LK, LR, LS, LT, LU, LV, MA, MD, MG, MK, MN, MW, MX, MZ, NO, NZ, OM, PH, PL, PT, RO, RU, SD, SE, SG, SI, SK, SL, TJ, TM, TN, TR, TT, TZ, UA, UG, UZ, VN, YU, ZA, ZM, ZW, ARIPO patent (GH, GM, KE, LS, MW, MZ, SD, SL, SZ, TZ, UG, ZM, ZW), Eurasian patent (AM, AZ, BY, KG, KZ, MD, RU, TJ, TM), European patent (AT, BE, CH, CY, DE, DK, ES, FI, FR, GB, GR, IE, IT, LU, MC, NL, PT, SE, TR), OAPI patent (BF, BJ, CF, CG, CI, CM, GA, GN, GQ, GW, ML, MR, NE, SN, TD, TG)

Published:

— without international search report and to be republished upon receipt of that report

For two-letter codes and other abbreviations, refer to the "Guidance Notes on Codes and Abbreviations" appearing at the beginning of each regular issue of the PCT Gazette.

ELECTRIC LANCET ACTUATOR

TECHNICAL FIELD

Lancing devices are known in the medical health-care products industry for piercing the skin to produce blood for analysis. Biochemical analysis of blood samples is a diagnostic tool for determining clinical information. Many point-of-care tests are performed using capillary whole blood, the most common being monitoring diabetic blood glucose level. Other uses for this method include the analysis of oxygen and coagulation based on Prothrombin time measurement. Typically, a drop of blood for this type of analysis is obtained by making a small incision in the fingertip, creating a small wound, which generates a small blood droplet on the surface of the skin.

BACKGROUND ART

Early methods of lancing included piercing or slicing the skin with a needle or razor. Current methods utilize lancing devices that contain a multitude of spring, cam and mass actuators to drive the lancet. These include cantilever springs, diaphragms, coil springs, as well as gravity plumbs used to drive the lancet. Typically, the device is pre-cocked or the user cocks the device. The device is held against the skin and mechanically triggers the ballistic launch of the lancet. The forward movement and depth of skin penetration of the lancet is determined by a mechanical stop and/or dampening, as well as a spring or cam to retract the lancet. What has been needed is a lancet and method of using the lancet that provides a desired amount of control over the lancing procedure.

DISCLOSURE OF INVENTION

Embodiments of the present invention are related to medical health-care products and to methods for obtaining body fluids for chemical analysis. More particularly, embodiments of the invention relate to devices and methods for piercing the skin (lancing) using an electrically driven lancet.

In an embodiment of the invention, an electric lancet actuator provides drive control of the lancet used for sampling blood by puncturing the skin. The lancet is contained within a stationary housing, which interacts with the proximal or driving end of the lancet, and allows the distal or front end of the lancet to protrude beyond the stationary housing and puncture the skin. Electric field coils drive the lancet using either magnetic attraction or repulsion. An iron flag or iron core or other magnetically permeable material is attached to the lancet to complete the magnetic circuit of the field coils. The iron flag is perforated with slits to create the magnetic bars of the same pitch as the field coils. An insulating housing provides a smooth low friction guide surface for the flag, and protects the lancet from touching the electric field coils and conducting electric current to the skin. Rivets, which connect the insulating housing to the stationary housing, bridge between the electric field coils and behave as poles.

A method for sampling blood through the skin uses the electric lancet driver to puncture the skin and retract the lancet with control on both the entry and the exit of the lancet from the skin.

BRIEF DESCRIPTION OF DRAWING

The objects, advantages and features of this invention will be more readily appreciated from the following detailed description, when read in conjunction with the accompanying drawing, in which:

Figures 1A - 1C are graphs of lancet velocity versus position for spring driven, cam driven, and electrically driven actuation methods.

Figure 2 illustrates a flat electric lancet actuator using a solenoid configuration to drive the lancet.

Figure 3 illustrates a cylindrical electric lancet actuator using a different configuration of solenoid to drive the lancet.

BEST MODE FOR CARRYING OUT THE INVENTION

Variations in skin thickness (stratum corneum) and hydration of the epidermis can yield different results from different users of existing lancing devices. Current

devices rely on adjustable mechanical stops or damping, to control the lancet's depth of penetration.

Common displacement profiles for both spring driven and cam driven devices are shown in Figures 1A and 1B, respectively. Velocity is plotted against displacement (X) of the lancet. Figure 1A represents typical spring driven devices (e.g. Becton Dickinson launcher). The lancet exit velocity increases until the lancet hits the surface of the skin (10). Because of the tensile characteristics of the skin, it will bend or deform until the lancet tip cuts the surface (12), the lancet will then penetrate the skin until it reaches a full stop (14). At this point displacement is maximal (limit of penetration) and the lancet stops. Mechanical stops absorb excess energy from the actuator and transfer it to the lancet body. The energy can cause both recoil resulting in multiple piercing (as seen by coiled profile in Figure 1A) and unnecessary pain as well as transferring vibratory energy into the skin and exciting nerve endings causing unnecessary pain. Retraction of the lancet then occurs and the lancet exits the skin (16) to return into the housing. Because of this type of spring driven actuation mechanism, velocity cannot be controlled.

Figure 1B shows that cam driven devices (such as Softclix®) have similar velocity versus displacement profiles, but because the return path is specified in the cam configuration, there is no possibility of multiple firings from one actuation. Cam based devices do offer some level of control of lancet velocity, but are unable to compensate for individual skin characteristics.

Advantages are achieved by utilizing an electric drive as an actuator for the lancet to achieve a velocity versus position profile as shown in Figure 1C. Embodiments of the present invention allow for the ability to accurately control depth of penetration, to control lancet withdrawal velocity, and reduce the pain perceived when cutting into the skin. Embodiments of the invention can be used with position feedback to control the power delivered to the lancet and optimize the velocity and displacement profile to compensate for variations in skin thickness and hydration, as described in a copending application (Attorney Docket Number 38187-2558, Inventors: Dominique Freeman, et al., entitled "SELF OPTIMIZING LANCING DEVICE WITH ADAPTATION MEANS TO TEMPORAL VARIATIONS IN CUTANEOUS PROPERTIES") submitted on the

same day and assigned to the same assignee as the present application. Said copending application is incorporated by reference in its entirety herein.

Pain reduction is achieved through both the rapid lancet cutting speed and a lightweight lancet. The rapid cutting minimizes the shock waves produced when the lancet strikes the skin in addition to compressing the skin for efficient cutting. Due to the very light mass of the lancet and lack of a mechanical stop, there is no vibrational energy transferred to the finger during cutting.

The lancing devices such as those whose velocity versus position profiles one shown in Figures 1A and 1B typically yield 70 – 80% success rate in obtaining a blood droplet, as some lancing events are unsuccessful. Success rate is dependent on reaching the blood capillaries and venuoles which yield the blood sample. Due to variations in skin thickness and hydration, some types of skin will deform more before cutting starts, and hence the actual depth of penetration will be less, resulting in less capillaries and venuoles cut. An electric lancet actuator controls the depth of penetration and improves the success rate of blood yield. Furthermore, the electric lancet allows slower retraction of the lancet, as described in a copending application (Attorney Docket Number 38187-2556, Inventors: Boecker, et al., entitled "METHOD AND APPARATUS FOR IMPROVING SUCCESS RATE OF BLOOD YIELD FROM A FINGERSTICK") submitted on the same day and assigned to the same assignee as the present application. Said copending application is incorporated by reference in its entirety herein.

Spontaneous blood yield occurs when blood from the cut vessels flow up the wound tract to the surface of the skin, where it can be collected and tested. Tissue elasticity parameters may force the wound tract to close behind the retracting lancet preventing the blood from reaching the surface. If however, the lancet were to be withdrawn slowly from the wound tract, thus keeping the wound open, blood could flow up the patent channel. Hence the ability to control the lancet speed into and out of the wound allows the device to compensate for changes in skin thickness and variations in skin hydration and thereby achieves spontaneous blood yield with maximum success rate while minimizing pain.

Electronic actuation is achieved by using an electromagnetic driver coupled directly to the lancet minimizing the mass of the lancet and allowing the driver to bring

the lancet to a stop at a predetermined depth without the use of a mechanical stop. Alternatively, if a mechanical stop is required for positive positioning, the energy transferred to the stop can be minimized. The electromagnetic driver allows programmable control over the entire lancing process including timing the start of the lancet, tracking the lancet position, measuring the lancet velocity, controlling the distal stop acceleration, and controlling the skin penetration depth.

Reference will now be made in detail to the exemplary embodiments of the invention, examples of which are illustrated in Figures 2 and 3. Wherever possible, the same reference numbers will be used throughout the drawings to refer to the same or like parts.

Figure 2 depicts an embodiment for the electric lancet actuator. Lancet is defined generally to include any sharp or blunt member, preferably having a relatively low mass, used to puncture the skin for the purpose of cutting blood vessels and allowing blood to flow to the surface of the skin. Electric lancet actuator is defined generally to include any device that moves a lancet under an electrically induced force. Figure 2 is a partially exploded view of an electric lancet actuator. The top half of the driver is shown assembled. The bottom half of the driver is shown exploded for illustrative purposes.

Figure 2 shows the inner insulating housing (22) separated from the stationary housing (20), and the lancet (24) and flag (26) assembly separated from the inner insulating housing (22) for illustrative purposes. In addition, only four rivets (18) are shown as attached to the inner insulating housing (22) and separated from the stationary housing (20). In an embodiment, each coil drive field core in the PC board located in the stationary housing (20) and (30) is connected to the inner insulating housing (22) and (32) with rivets.

The electric lancet actuator has a moving part comprising a lancet assembly with a lancet (24) and a magnetically permeable flag (26) attached at the proximal or drive end and a stationary part comprising a stationary housing assembly with electric field coils arranged so that they produce a balanced field at the flag to reduce or eliminate any net lateral force on the flag. Electric field coil means one or more metal coils which generate a magnetic field when electric current passes through the metal. Iron

flag is generally defined to mean any flat or enlarged piece of magnetic material which increases the surface area of the lancet assembly to enhance the electromotive forces generated between the proximal end of the lancet and the field coils. Preferably, the combined mass of the lancet and the iron flag are minimized to facilitate rapid acceleration for introduction into the skin, to reduce the impact when the lancet stops in the skin, and to facilitate prompt velocity profile changes throughout the sampling cycle.

The stationary housing assembly consists of a lower stationary housing (20), a lower inner insulating housing (22), an upper inner insulating housing (32), an upper stationary housing (30), and rivets (18) assembled into a single unit. The lower and upper inner insulating housing (22) and (32) are relieved to form a slot so that lancet assembly can be slid into the driver assembly from the side perpendicular to the direction of the lancet's advancement and retraction. This allows the disposal of the lancet assembly and reuse of the stationary housing assembly with another lancet assembly while avoiding accidental lancet launches during replacement.

The electric field coils in the upper and lower stationary housing (20) and (30) are fabricated in a multi-layer printed circuit (PC) board. They may also be conventionally wound wire coils. A Teflon® (or other lubricious insulating material) is used to construct the lower and upper inner insulating housing (22) and (32). Each insulating housing is mounted on the PC board to provide electrical insulation and physical protection, as well as to provide a low-friction guide for the lancet. The lower and upper inner insulating housing (22) and (32) provide a reference surface with a small gap so that the lancet assembly (24) and (26) can align with the drive field coils in the PC board for good magnetic coupling. Rivets (18) connect the lower inner insulating housing (22) to the lower stationary housing (20) and are made of magnetically permeable material such as ferrite or steel, which serves to concentrate the magnetic field. This mirrors the construction of the upper inner insulating housing (32) and upper stationary housing (30). These rivets form the poles of the electric field coils. The PC board is fabricated with multiple layers of coils or with multiple boards. Each layer supports spiral traces around a central hole. Alternate layers spiral from the center outwards or from the edges inward. In this way each layer connects via simple feed-

through holes, and the current always travels in the same direction, summing the ampere-turns.

The PC boards within the lower and upper stationary housings (20) and (30) are connected to the lower and upper inner insulating housings (22) and (32) with the rivets (18). The lower and upper inner insulating housings (22) and (32) expose the rivet heads on opposite ends of the slot where the lancet assembly (24) and (26) travels. The magnetic field lines from each rivet create magnetic poles at the rivet heads. An iron bar on the opposite side of the PC board within each of the lower and upper stationary housing (20) and (30) completes the magnetic circuit by connecting the rivets. To complete the magnetic circuit an iron bar is needed between the rivets of a magnetic coil pair. In operation, the magnetically permeable flag (26) attached to the lancet (24) is divided into slits and bars (34). The slit patterns are staggered so that the flag (26) can be driven by coils in two, three or more phases.

Both lower and upper stationary housing (20) and (30) contain PC boards so that there is a symmetrical magnetic field above and below the flag (26). When the pair of PC boards is turned on, a magnetic field is established around the bars between the slits of the magnetically permeable iron on the flag (26). The bars experiences a force that tends to move the magnetically permeable material to a position minimizing the number and length of magnetic field lines and conducting the magnetic field lines between the magnetic poles.

When a bar of the flag (26) is centered between the rivets (18) of a magnetic pole, there is no net force on the flag, and any disturbing force is resisted by imbalance in the field. This embodiment of the device operates on a principle similar to that of a solenoid. Solenoids cannot push by repelling iron; they can only pull by attracting the iron into a minimum energy position. The slits (34) on one side of the flag (26) are offset with respect to the other side by approximately one half of the pitch of the poles. By alternately activating the coils on each side of the PC board, the lancet assembly can be moved with respect to the stationary housing assembly. The direction of travel is established by selectively energizing the coils adjacent the metal flag on the lancet assembly. Alternatively, a three phase, three-pole design or a shading coil that is offset by one-quarter pitch establishes the direction of travel. The lower and upper stationary

housing (20) and (30) shown in Figure 2 contain the PC boards with electric field coils, which drive the lancet assembly and the circuitry for controlling the entire electric lancet activator.

5 The embodiment described above is a magnetic attraction drive, similar to commonly available circular stepper motors (Hurst Manufacturing BA Series motor, or "Electrical Engineering Handbook" Second edition p 1472-1474, 1997). These references are hereby incorporated by reference. Another embodiment is a linear induction drive that uses a changing magnetic field to induce electric currents in the lancet assembly. These induced currents produce a secondary magnetic field that repels
10 the primary field and applies a net force on the lancet assembly. The linear induction drive uses an electrical drive control that sweeps a magnetic field from pole to pole, propelling the lancet before it. Varying the rate of the sweep and the magnitude of the field by altering the driving voltage and frequency controls the force applied to the lancet assembly and its velocity. The arrangement of the coils and rivets to concentrate
15 the magnetic flux also apply to the induction design creating a growing magnetic field as the electric current in the field switches on. This growing magnetic field creates an opposing electric current in the conductive flag. In a linear induction motor the flag is electrically conductive, and its magnetic properties are unimportant. Copper or aluminum are materials that can be used for the conductive flags. Copper is generally
20 used because of its good electrical conductivity. The opposing electrical field produces an opposing magnetic field that repels the field of the coils. By phasing the power of the coils, a moving field can be generated which pushes the flag along just below the synchronous speed of the coils. By controlling the rate of sweep, and by generating multiple sweeps, the flag can be moved at a desired speed.

25 Figure 3 shows another solenoid type electric lancet actuator that is capable of driving an iron core mounted to the lancet assembly using a direct current (DC) power supply. The solenoid is divided into three separate coils along the path of the lancet, two end coils and a middle coil. Direct current is alternated to the coils to advance and retract the lancet.

30 The stationary iron housing (40) contains the solenoid whose first coil (52) is flanked by iron spacers (50) which concentrate the magnetic flux at the inner diameter

creating magnetic poles. The inner insulating housing (48) isolates the lancet (42) and iron core (46) from the solenoids (52) and provides a smooth, low friction guide surface. The lancet (42) and iron core (46) are further centered by the lancet guide (44). The lancet (42) is protracted and retracted by alternating the current between the first coil (52), the middle coil, and the third coil to attract or repulse the iron core (46). The lancet is retracted by reversing the coil sequence and attracting the core and lancet back into the housing. The lancet guide (44) also serves as a stop for the iron core (46) mounted to the lancet (42).

Other embodiments of the invention will be apparent to those skilled in the art from consideration of the specification and practice of the invention disclosed herein. It is intended that the specification and examples be considered as exemplary only, with a true scope and spirit of the invention being indicated by the following claims.

CLAIMS

1. An electric lancet actuator comprising:
a lancet with a distal puncture end and a proximal driver end housed within a stationary housing, said housing comprising an electric energy source for driving said lancet along a predetermined path.
- 5 2. An electric lancet actuator according to claim 1 wherein:
said stationary housing further comprises electric field coils.
3. An electric lancet actuator according to claim 2 wherein:
an inner insulating housing separates said electric field coils from said lancet.
- 10 4. An electric lancet actuator according to claim 3 wherein:
said inner insulating housing contains rivets such that magnetic poles extend toward said lancet.
5. An electric lancet actuator according to claim 2 or claim 4 wherein:
a metal flag is attached at the proximal driver end of said lancet.
- 15 6. An electric lancet actuator according to claim 5 wherein:
said metal flag is perforated with slits.
7. An electric lancet actuator according to claim 2 wherein:
said electric field coils are disposed on a printed circuit board.
8. An electric lancet actuator according to claim 2 wherein:
said electric field coils move said lancet by generating an electromotive force.

9. An electric lancet actuator according to claim 2 wherein:
said electric field coils drive said lancet by application of alternating electromagnetic polarities.
10. An electric lancet actuator according to claim 2 wherein:
5 said electric field coils are configured as concentric solenoid coils.
11. An electric lancet actuator according to claim 10 wherein:
an inner insulating housing separates said solenoid coils and said lancet.
12. An electric lancet actuator according to claim 10 or claim 11 wherein:
an iron core is attached at the proximal driver end of said lancet.
- 10 13. An electric lancet actuator according to claim 10 wherein:
said solenoid coils move said movable lancet by generating an electromotive force.
14. An electric lancet actuator according to claim 10 wherein:
said solenoids drive said movable lancet by application of alternating
15 electromagnetic polarities.
15. An electric lancet actuator according to claim 1 wherein:
said movable lancet is removable from said stationary housing and is disposable.
16. An electric lancet actuator comprising:
a lancet for puncturing a piece of skin to cause the formation of a droplet of
20 blood; and
a source for generating electromagnetic energy to displace said lancet.

17. A method for sampling blood through a piece of skin comprising the steps of:
 - advancing a lancet with electromagnetic force from an electric lancet actuator
 - using an electric lancet actuator to propel a lancet into said skin; and
 - retracting said lancet with electromagnetic force from said electric lancet actuator.

Fig. 1A

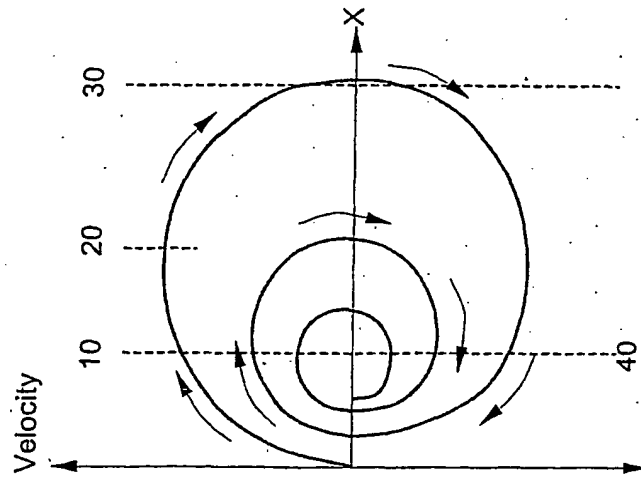

Fig. 1B

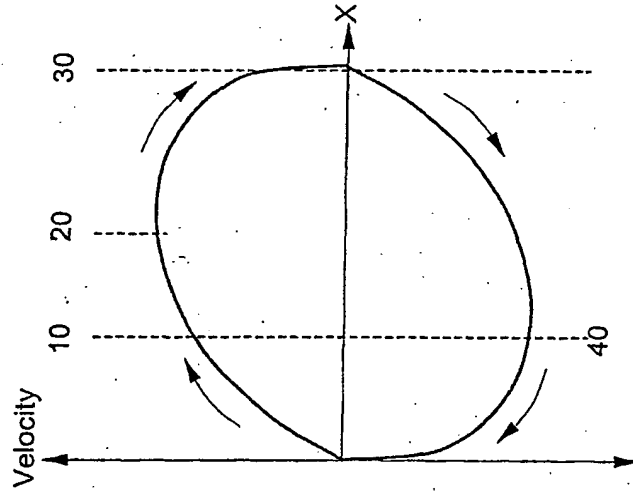
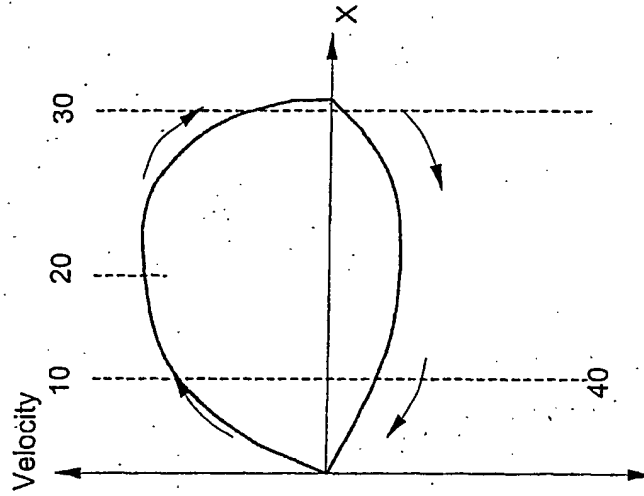

Fig. 1C



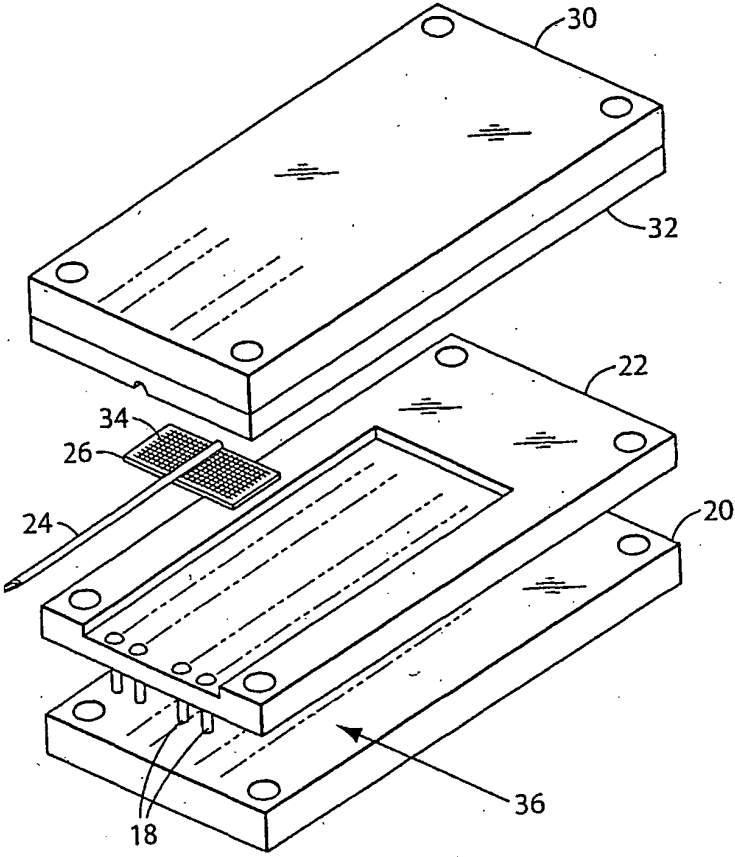

Figure 2

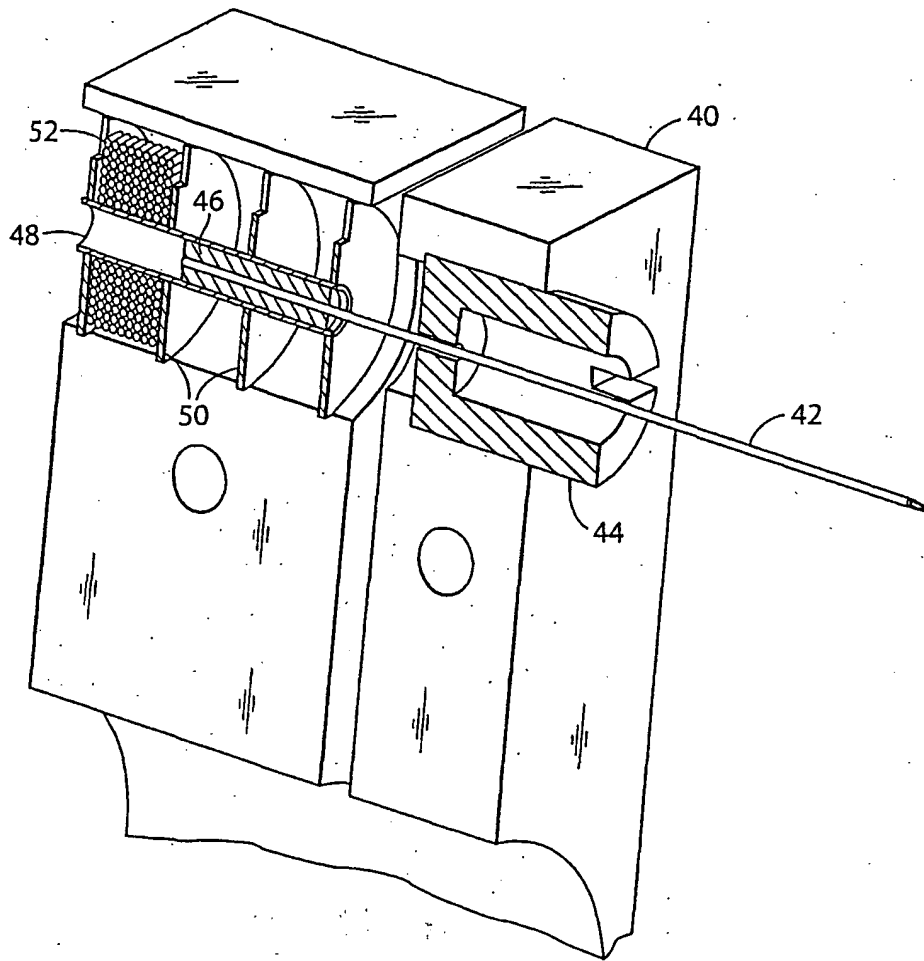

Figure 3

BLANK PAGE